

EXIT HARDWARE

The safe choice in exiting. High performance, high traffic devices that provide egress efficiency, freedom of movement and robust security.

VERSION 1.0



Abloy | UK

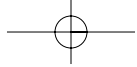

Introduction. With effortless efficiency and functionality, our range of JPM exit hardware provides the exacting design, construction and options to meet the demands of major public and industrial buildings.



MEETS EN1125 AND EN179

CORROSION RESISTANT, 96 HOUR SALT SPRAY TESTED

HIGH QUALITY, ELEGANT DESIGN

TESTED TO 250,000 CYCLES

LOW OPENING PRESSURE

QUICK AND SAFE EXIT

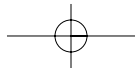
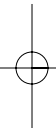
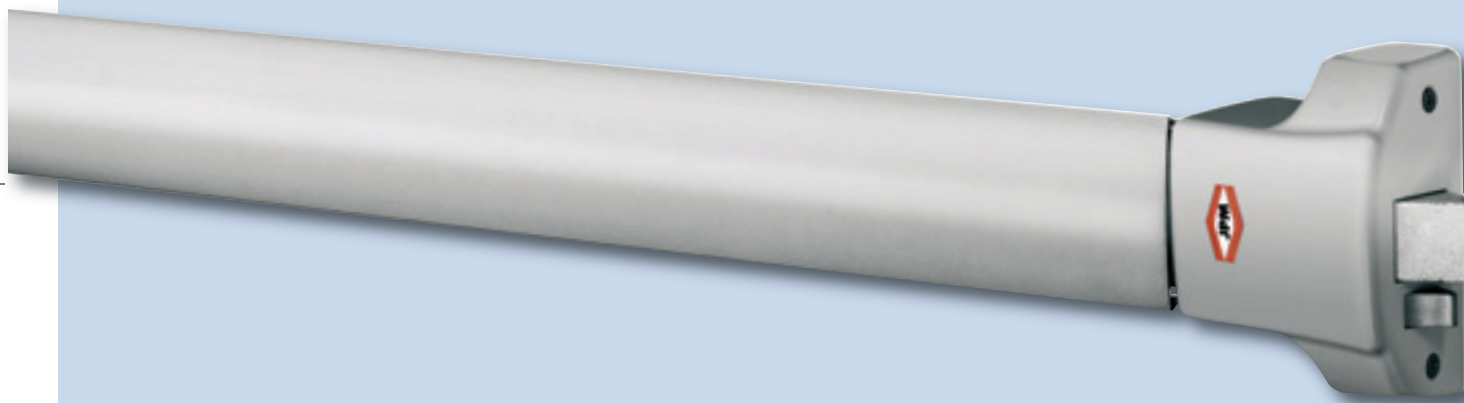

Freedom and control

The range of exit hardware offered by Abloy | UK is manufactured by JPM France – one of the world's leading experts in the field.

All commonly used variations of mechanical panic and emergency exit devices are available offering single, two point or three point locking. All products are resistant to corrosion (96 hour salt spray test) and mechanical products are designed to meet EN1125 panic exit or EN179 emergency exit device standards.

Strike plates for both types of normal installation are included with all products and additional strikes are available to suit specialist door situations.

All JPM products carry a five year warranty.



8901**Single panic latch****89 Series features**

- Door brackets only 42mm wide
 - Pivoting Pullman latches
 - Low opening pressure
 - Outside trim available (see page 14)
 - Cross follower on main case
 - Non-handed
 - Double rebated doors (8901 and 8902)
 - Automatic re-latching of bolts when door closes
- Horizontal bars and vertical rods can be cut to suit door size:
 - All 89 series panic bars are supplied 950mm total width as standard with 1250mm total width versions available to special order
 - 8902 and 8903 bars are supplied suitable for door heights of up to 2352mm
 - S91 extension accessory kit, on page 14, can extend upper vertical rods by up to 865mm for tall doors

Finish

Silver enamel (stainless steel and other finishes to special order)

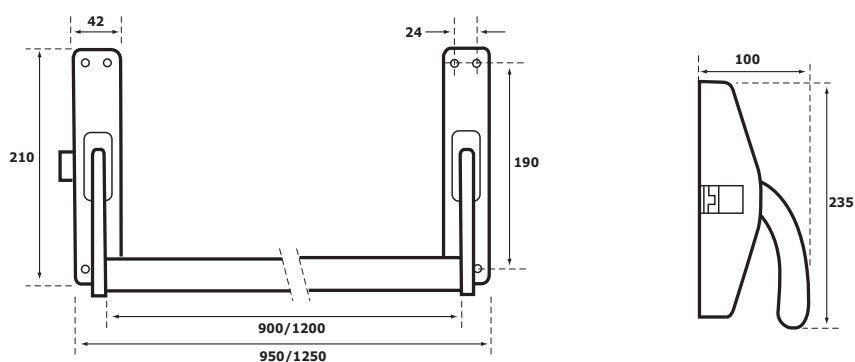

8902

Two point

Pullman latches top and bottom and covered rods

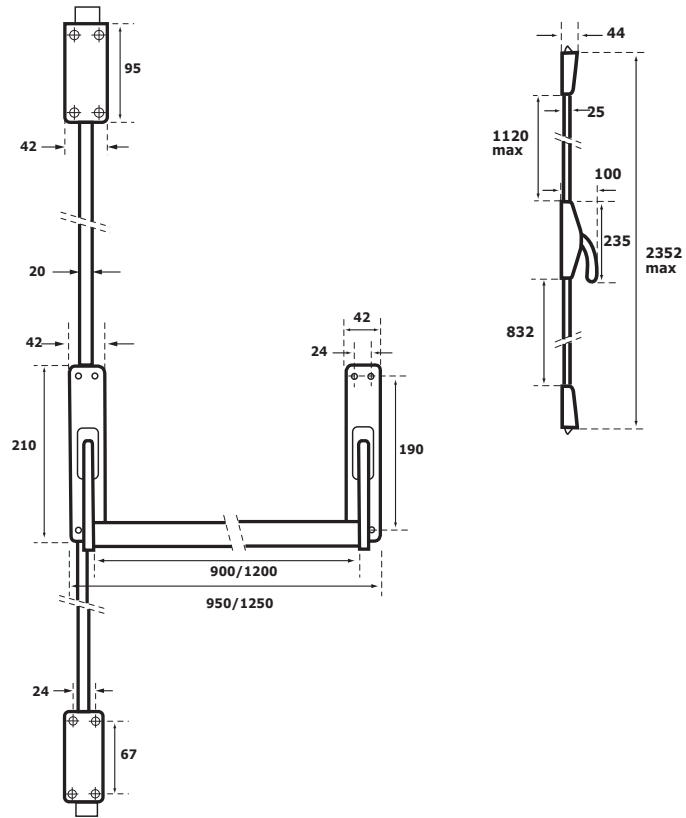

8903

Three point

Pullman latches top and bottom plus side latch and covered rods

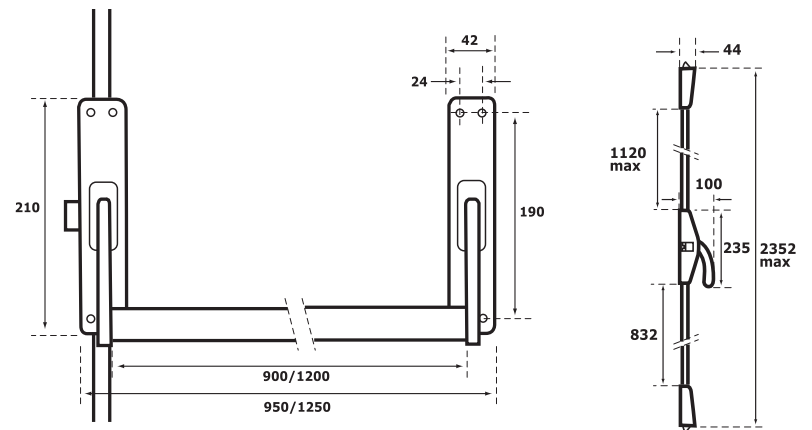

**990000 series
push bar**

Panic exit device

**Features**

- Push bar
- Low opening pressure
- Horizontal bars can be cut to size
- Push bar can also be used with the range of ABLOY DIN electric lockcases EL520 + EL420

Finish

Satin enamel (SE) as standard (stainless steel and RAL colours are available to special order)

EL520 Kit comprises of:

- EL520, 60, 65 or 55 mm backset*
- 990000-SE
- IK-SF01-42834
- CY303-PT-SC-DF

EL420 kit comprises of:

- EL420 35mm or 30 mm backset*
- 990001 SE
- IK-SF02-43026
- CY303-PT-SC-DF

* please specify backset when ordering

Kits available for 44mm and 54mm doors

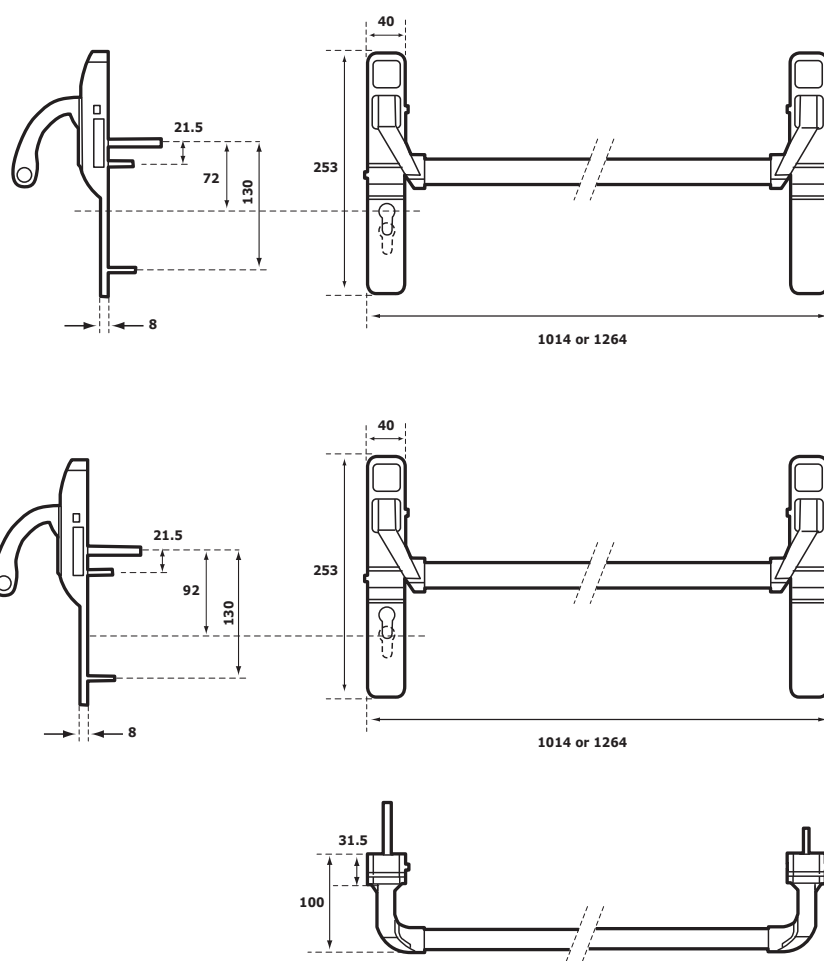

PJ1000

Single side latch



90+ Series features

- CE Product has been successfully type tested for conformity to EN 1125 classification 37511322A. Regular audit testing is undertaken
- Low projection of only 59mm from door
- Cannot be chained
- Automatic relatching
- Single and double door versions:
- Double rebated doors (9000 and 9300)
- Double non-rebated doors (9300 x2)
- Non-handed
- Deadlocking Pullman latches

- Mechanical dogging versions that accept single euro cylinders available to special order
- Outside trims available (see page 14)
- Cross follower on main case
- Horizontal bars and vertical rods can be cut to suit door size
- 1, 2 and 3 point locking

PJ1000, PJ2000 and PJ3000

Bars are supplied 838mm long, suitable for 900mm wide doors and can be cut down to a minimum length of 650mm

• 1141mm long versions, available to special order, suitable for 1200mm wide doors and can be cut down to a minimum length of 750mm

- PJ3000 and PJ2000panic bolt is supplied, as standard, to be suitable for door heights of up to 2300mm
- S91 extension accessory kit, on page 14, can extend upper vertical rods by up to 865mm for tall doors
- Cannot be chained

Finish

Silver enamel with black touch bar (other finishes to special order)

PJ2000

Panic bolt

Two point locking with covered rods and an anti drag mechanism on bottom bolt

PJ3000

3 point locking with covered rods and an anti drag mechanism on bottom bolt



Illustrated: special order silver enamel with silver touch bar

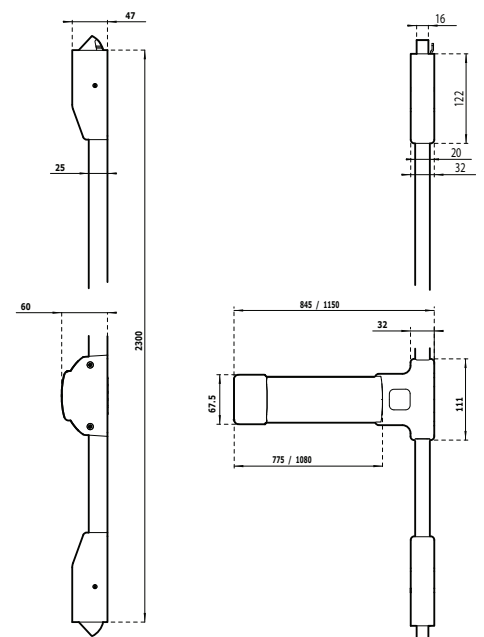
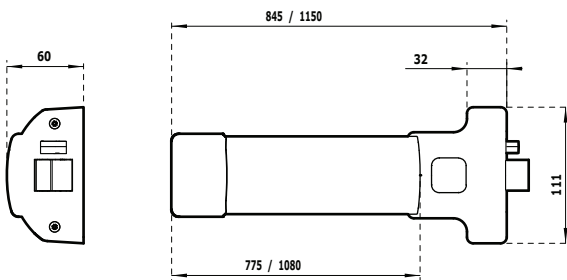

Evolution

900 Series

900101

Single latch with bar blocking

900111

Single latch with bar blocking and monitoring

930101

Two point with bar blocking

930111

Two point with bar blocking and monitoring

900310

Single latch with electric latch retraction and monitoring

900411

Single latch with bar blocking, electric latch retraction and monitoring

930310

Two point with electric latch retraction and monitoring

930411

Two point with bar blocking, electric latch retraction and monitoring

Concept

Evolution and 900 Series push control provides complete control over emergency exit doors through sophisticated electronics. The system uses the 90 Series touch bar and can provide both local and remote control of the unit via a control box connected to an opening device at the door, or by connecting a series of doors to a central station which can monitor the condition of all doors remotely. Systems are connected to the fire alarm so that egress is assured in the case of an emergency.

This range of electro-mechanical panic exit devices is designed to meet French regulations. However, in the UK and Ireland the use of exit hardware using electrical blocking must be approved by the local building control authorities.

Legislation

Push control will meet the following regulations:

- Conforms to EC Directive 89/336 EEC May 1989 and 92.587 June 1992 covering electro-magnetic compatibility (CE marked)

Features

- Tested in excess of 250,000 cycles
- One or two point locking
- Instant door release under 1,000N side load
- Low opening pressure <8kg
- Outside trim available (see opposite)
- Automatic deadlocking Pullman latches
- Anti-drag mechanism retains bottom bolt in housing when open
- Steel rod covers
- Evolution models can be cut on site for adjustment to door width
- 900 Series models are available in to sizes. Standard version can be cut from 1411mm to 820mm and special order 838mm to 635mm. Please specify when ordering



PRODUCT SPECIFICATION	EVOLUTION		900 SERIES	
	BAR BLOCKING	BAR BLOCKING + MONITORING	ELECTRIC LATCH RETRACTION + MONITORING	BAR BLOCKING + ELECTRIC LATCH RETRACTION + MONITORING
	EXIT CONTROL ONLY	EXIT CONTROL AND SYSTEM CONTROL	ENTRANCE AND SYSTEM CONTROL	EXIT, ENTRANCE AND SYSTEM CONTROL
Version				
Side latch 24V DC	900101	900111	900310	900411
Top/bottom bolts 24V DC	930101	930111	930310	930411

ELECTRICAL FEATURES	BLOCKING	BLOCKING + MONITORING	ELECTRIC LATCH RETRACTION + MONITORING	BLOCKING + ELECTRIC LATCH RETRACTION + MONITORING
Voltage 24V DC	•	•	•	•
Peak current 24V DC	←	2 amp total current draw at pull-in		→

Supplied standard

838mm (900mm door) can be cut by a maximum 150mm

Special order

- 1,141mm (1,200mm door) can be cut by a maximum 300mm
- Use S91 (865mm) extension pieces for very high doors (see page 14)
- CE compliant

Finish

900 series: Silver enamel with black touch bar

Evolution: Red enamel with black touch bar (other finishes available to special order)

Bar blocking

Bar electrically blocked when power on/released when power off

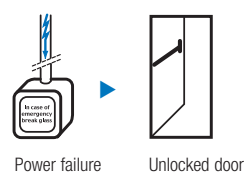
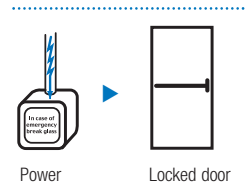

Electric latch retraction of bar and bolt

Motorised retraction of bar and bolt(s) to release door (reader or keypad can be used outside for access control). Normal mechanical operation inside at all times.



MONITORING/DETECTION DETAIL	STATUS OF DEVICE	DOOR STATUS*	MOTORISED LATCH/BOLTS	BAR OPERATION (RQE)	PROBLEM
Blocking	•	•		•	
Electric latch retraction		•	•	•	•
Blocking + electric latch retraction	•	•	•	•	•

* When fitted with door contacts

E82100**Security panic latch****FAP 8 features**

- CE Product has been successfully type tested for conformity to EN 1125 classification 37611422B. Regular audit testing is undertaken
- Deadlocking clawbolt action withstands an attack force of 982kg
- Low projection of 78mm from the door
- Very low operating pressure makes it particularly suitable for use by small children and door users with additional needs
- Non-handed
- Smooth and silent operation

- For double rebated doors use E82100 and E82200
- For non-rebated doors use 2 x E82200
- Outside trim available see page 14
- Horizontal bars and vertical rods can be cut to suit door size

E82100/E82200/E82300

- Bars are supplied 850mm long, suitable for 900mm wide doors and can be cut down to a minimum length of 450mm

E82110/E82210/E82310

- 1150mm long versions, available to special order, suitable for 1200mm wide doors and can be cut down to a minimum length of 450mm
- FAP 8 panic bars are supplied, as standard, to be suitable for door heights of up to 2455mm
- Extension kit available for doors over 2455mm (KE8000-01/03-0A)

Finish

Silver (S) or stainless steel (SS) bar with anthracite body as standard. (black, white, red and green bar finishes are available to special order)

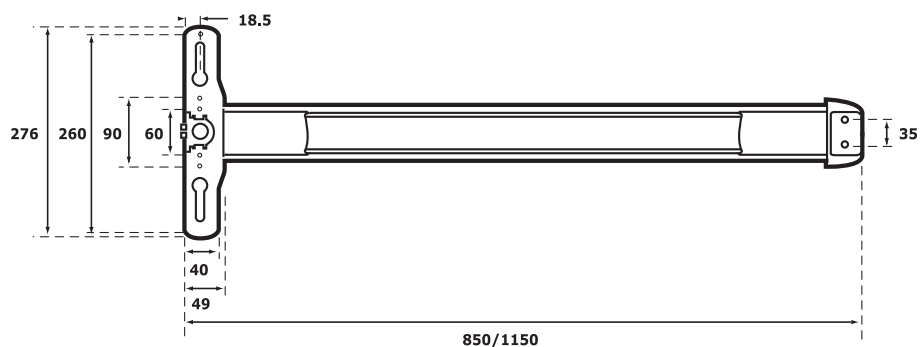

Used where safety and efficiency is critical. Abloy | UK exit hardware is widely specified for high traffic business and public environments where safety cannot be compromised.



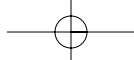

E82200

Two point locking security panic bar



E82300

Three point locking security panic bar

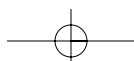
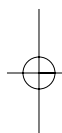
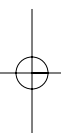
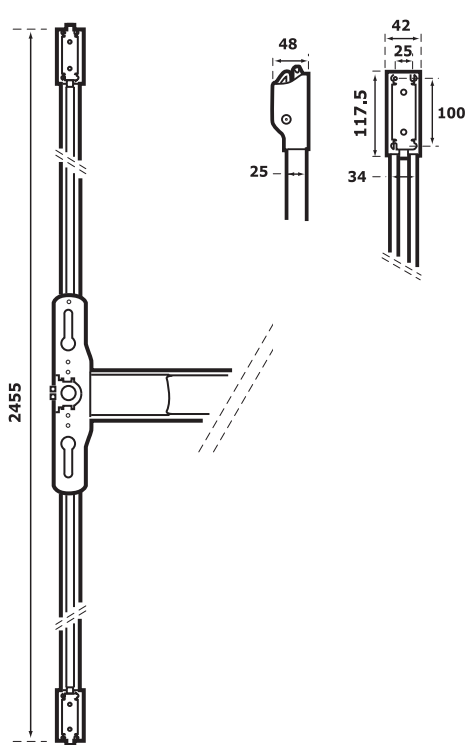
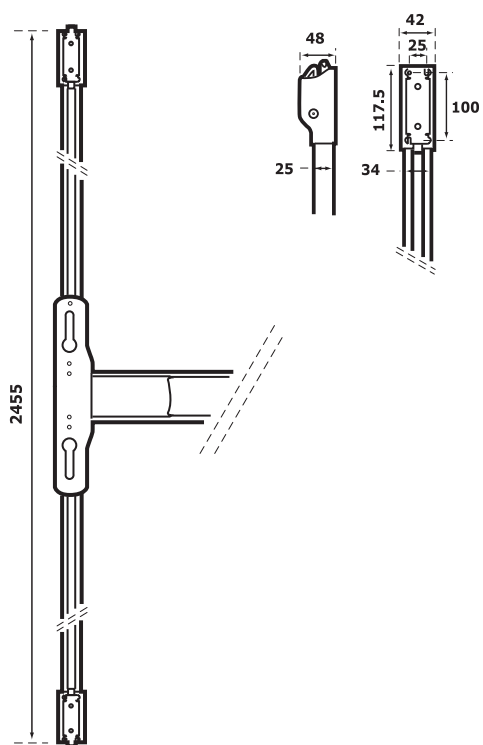

8989**Europad emergency exit device****Features**

- CE Product has been successfully type tested for conformity to EN 179 classification 37511322B. Regular audit testing is undertaken.
- Low opening pressure – <8kg
- 2 point automatic relatching
- Suitable for door heights of up to 2352mm

- Top rod can be extended with S91 kit see page 14.
- Outside trim available see page 14.

Finish

Silver with black pad (other finishes to special order)

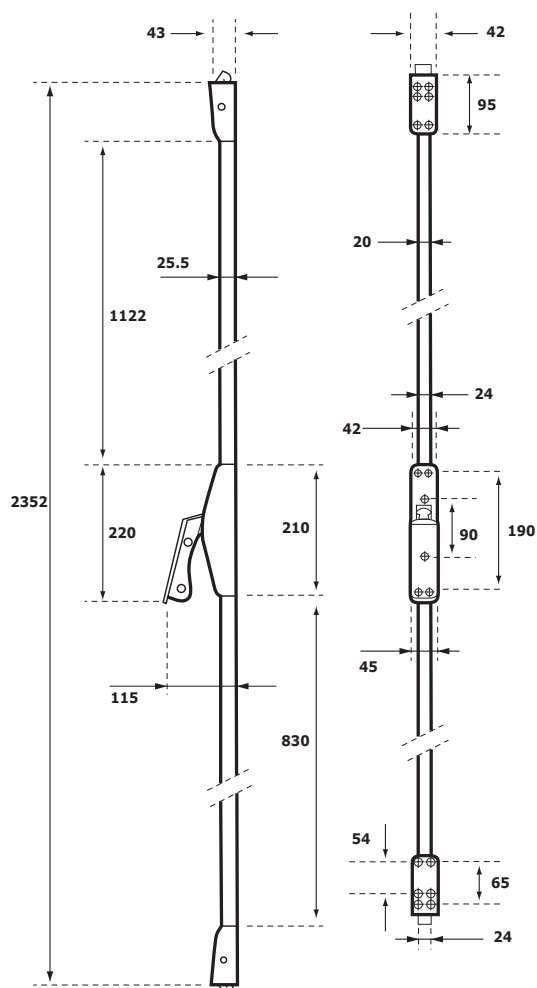

EN3000**Outside trim with lever handle****EN3300****Outside trim with knob****S91****Extension kit**

Suitable for FAP 89 and FAP 90 series panic bars

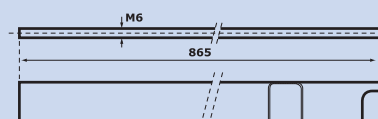
**Extension kit for thicker doors**

JPM-KE-2000 extends EN3000 to 80mm thick doors.

STRIKES

Strike plates for special applications, such as PVCu doors; details available on request

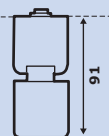
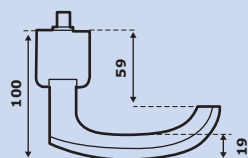
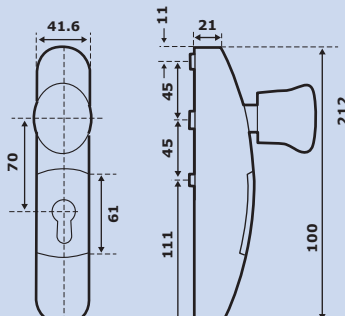
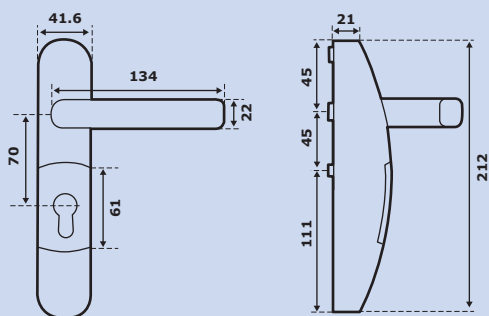
**EN3000 and EN3300 outside trim features**

- Suitable for FAP8, FAP89, FAP90 series panic devices and Europad 179 series
- Reversible lever handle/knob disengages if excessive force applied (>15N)
- Non handed
- Selectable, at installation, key retaining option, which holds the key captive if the handle has been unlocked.
- Lever Handle disengages at 45Nm as an anti-vandal measure and is easily reset to its horizontal position.
- Requires the addition of a single Euro cylinder, see ABLOY CY303,307,313 or 317. Cylinder can be changed without removing the outside trim.
- Bolt through fixing allows the trim to be used with all door materials and types up to 65mm thick

Finish





Silver standard. Stainless steel and other finishes to special order.



Abloy | UK

Abloy | UK
 Abloy House
 Hatters Lane
 Croxley Green Business Park
 Watford, Hertfordshire
 WD18 8QY

Phone 01923 255066
 Fax 01923 230281
 Email sales@abloysecurity.co.uk
www.abloy.co.uk

LET ABLOY UK HELP	1: ONLINE	2: ON THE PHONE	3: ON SITE	4: PLANNING	5: IMPLEMENTATION
<p>Abloy UK are always on hand with courteous and expert help, right from supply and support of our products to planning and implementation of major projects.</p>	 www.abloy.co.uk Our a state of the art, customer focused website. Just click for product information, technical data, downloads and more	 01923 255066 Courteous and knowledgeable telephone assistance, whether for sales, consultancy or technical matters	 01923 255066 Friendly on site consultancy for larger projects	 01923 255066 Experienced assessment and planning of your project	 01923 255066 Implementation of your installation through our national network of Centres, selected by us for specific product and technical disciplines

Due to a continuous programme of development, Abloy | UK reserves the right to make alterations without notice. For technical reasons connected with colour reproduction the colours shown may vary slightly from those of the product. All dimensions provided within this catalogue are approximate and for guidance only.

E. & O. E. For terms and conditions of sale, please refer to the current price list.

Abloy | UK markets high quality products and accessories for security applications. Our customer base provides solutions to a broad spectrum of public and private organisations throughout the UK and Ireland.



ISO9001:2000
 Certificate number FS504352



The ASSA ABLOY Group is the world's leading manufacturer and supplier of locking solutions, dedicated to satisfying end-user needs for security, safety and convenience.